

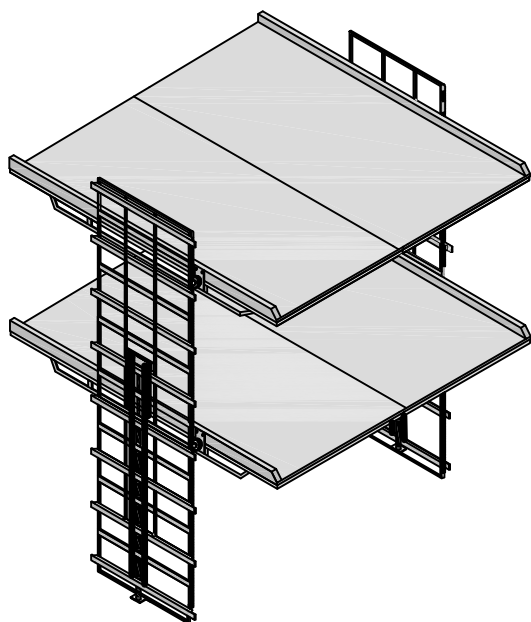

GREEN PARK srl
SISTEMI DI PARCHEGGIO

parcheggio parallelo a posti indipendenti MOD GP-T4

PARALLEL PARKING WITH INDEPENDENT PLACES "GP-T4 MODEL"



PARCHEGGIO MODULARE A SCOMPARSA CON PIANALI PARALLELI ZINCATI A CALDO. QUESTO TIPO DI IMPIANTO PUO' SERVIRE DUE, TRE, QUATTRO O SEI POSTI AUTO INDIPENDENTI POSTI SU DUE O TRE LIVELLI.

MODULAR RETRACTABLE PARKING WITH PARALLEL HOT GALVANIZED PLATFORMS. THIS KIND OF SYSTEM CAN BE USED FOR TWO, THREE, FOUR OR SIX INDEPENDENT CAR PLACES, POSITIONED ON TWO OR THREE LEVELS.

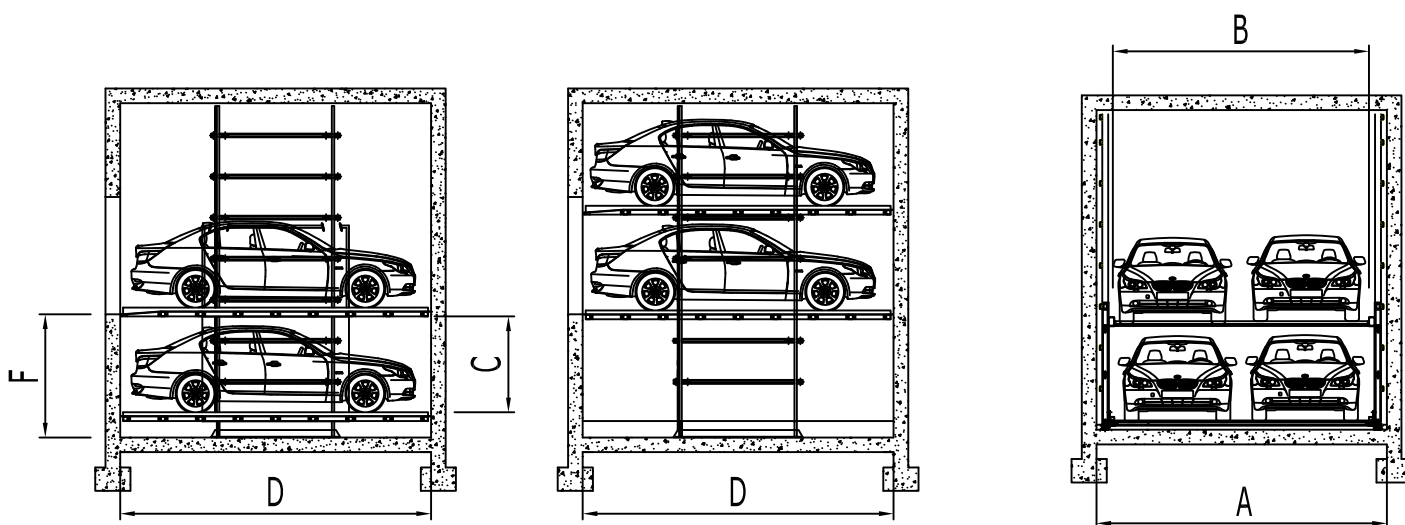

MODELLO MODEL	FOSSA F HOLE DEPHT	LARGH. A WIDTH	LUNGH. D LENGHT	UTILE PIANALE B USEFUL PLATFORM	INTERPIANO C INTERMEDIATE FLOOR	PORTATA POSTO AUTO CAPACITY PER CAR PLACE	PESO WEIGHT	TENSIONE TENSION
SMALL	1900-2300	5100	5360	4600	1600-2000	2500	5400	380 volt
STANDARD	1900-2300	5200	5360	4700	1600-2000	2500	5500	380 volt
LARGO	1900-2300	5300	5360	4800	1600-2000	2500	5600	380 Volt
EXTRALARGO	1900-2300	5400	5360	4900	1600-2000	2500	5700	380 Volt

MISURE ESPRESSE IN mm PESO E PORTATATA IN Kg

(La greenpark srl si riserva il diritto di apportare modifiche alle specifiche tecniche)
(La green reserves the right to modify the technical specifications)

green park srl - via 8 marzo ,18 -25013 carpednolò (bs) - tel.030/9698822 fax 030/969303
www.greenparksrl.it mail: info@greenparksrl.it

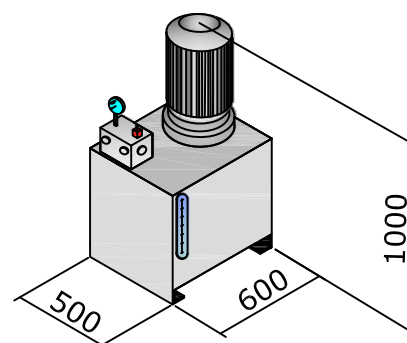
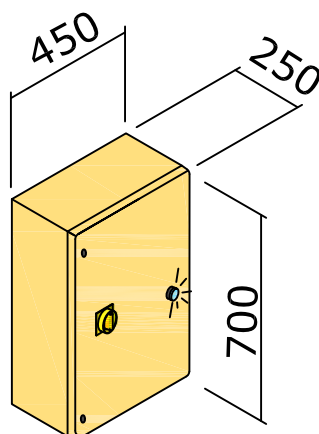
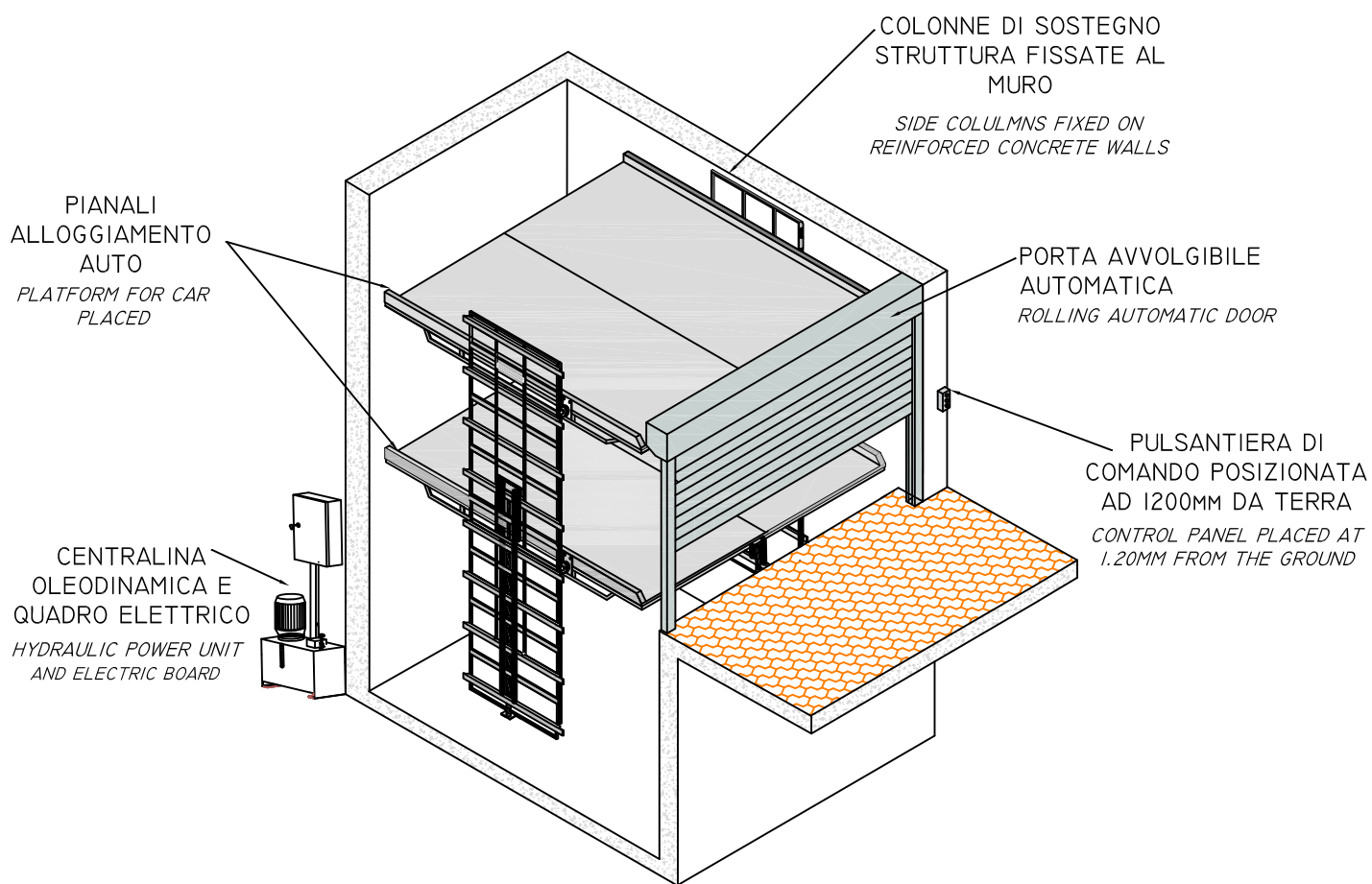

MOTORE TIPO KIND OF ENGINE	POTENZA POWER		TENSIONE ELETTRICA ELECTRIC VOLTAGE (V)	GIRI MOTORE ENGINE RMP (g/1')	ASSORB. SPUNTO STARTING ABSORP. (A)	ASSORB. A REGIME FUNCTIONING ABSORP. (A)
	(kW)	(HP)				
centralina	4	5.5	380 Volt	1400	14.5	9-10

LE SEGUENTI QUOTE SONO RIFERITE AL MODELLO T2 LARGO
THE FOLLOWING LEVELS ARE REFERRED TO THE WIDE GP-T2 MODEL

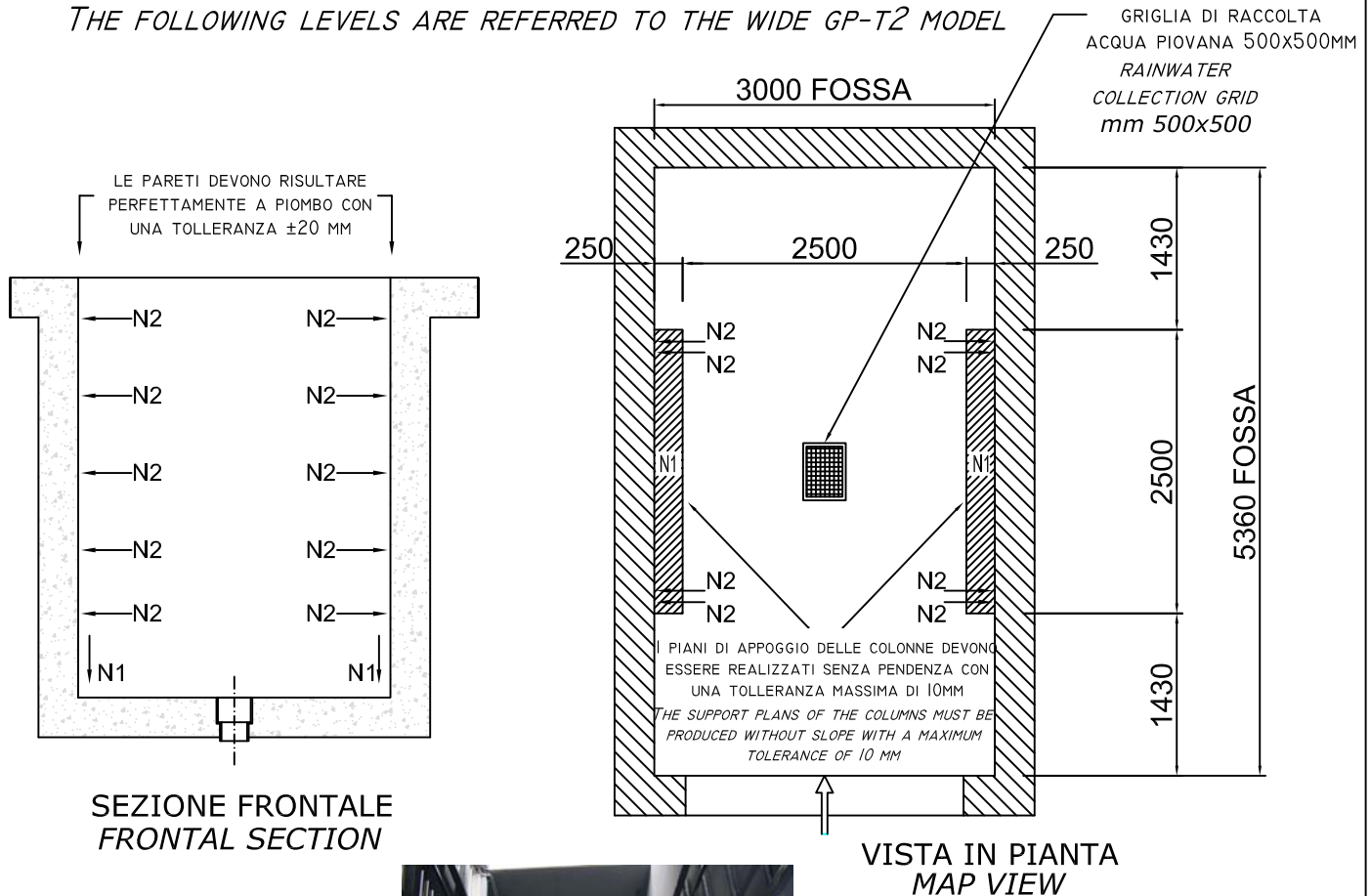

COLONNE LATERALI FISSATE SU PARETE DI CEMENTO ARMATO
SIDE COLUMNS FIXED ON REINFORCED CONCRETE WALLS



RETI DI PROTEZIONE
PROTECTIVE NETS

TABELLA DI ANALISI DEI CARICHI CHARGES ANALYSIS

MODELLO MODEL	DIMENSIONI DEL VANO SIZE OF THE COMPARTMENT	CARICO PERMANENTE DEL MACCHINARIO MAX (kN) MACHINE PERMANENT CHARGE	CARICO ACCIDENTALE VETTURA (kN) ACCIDENTAL CHARGE	CARICO TOTALE TOTAL LOAD
SMALL	2800x5360	24	29	53
STANDARD	2900x5360	24.5	31	55.5
LARGO	3000x5360	25	33	58
EXTRALARGO	3100x5360	26.5	35	61.5

SMALL	
N1=27.3 kN	N1=2730 Kg
N2=0.42 kN	N2=42 Kg

STANDARD	
N1=29 kN	N1=2900 Kg
N2=0.45 kN	N2=45 Kg

LARGO	
N1=30.7 kN	N1=3070 Kg
N2=0.50 kN	N2=50 Kg

EXTRALARGO	
N1=32.7 kN	N1=3270 Kg
N2=0.53 kN	N2=53 Kg

